

IEEE Standard Procedure for the Determination of the Ampacity Derating of Fire-Protected Cables

Sponsor

**Insulated Conductors Committee
of the
IEEE Power Engineering Society**

Approved 5 August 1996
IEEE Standards Board

Abstract: A detailed test procedure is provided for determining the ampacity or derating factor in the following cable installation configurations: block-out or sleeve type cable penetration fire stops; conduits covered with a protective material; tray covered with a protective material; cable directly covered or coated with a fire-retardant material; and free-air drops enclosed with a protective material.

Keywords: ampacity derating factor, cable penetration fire stops, electrical separation wrap systems, fire-protected cable system, fire protected conduits

The Institute of Electrical and Electronics Engineers, Inc.
345 East 47th Street, New York, NY 10017-2394, USA

Copyright © 1996 by the Institute of Electrical and Electronics Engineers, Inc.
All rights reserved. Published 1996. Printed in the United States of America.

ISBN 1-55937-780-1

No part of this publication may be reproduced in any form, in an electronic retrieval system or otherwise, without the prior written permission of the publisher.

IEEE Standards documents are developed within the IEEE Societies and the Standards Coordinating Committees of the IEEE Standards Board. Members of the committees serve voluntarily and without compensation. They are not necessarily members of the Institute. The standards developed within IEEE represent a consensus of the broad expertise on the subject within the Institute as well as those activities outside of IEEE that have expressed an interest in participating in the development of the standard.

Use of an IEEE Standard is wholly voluntary. The existence of an IEEE Standard does not imply that there are no other ways to produce, test, measure, purchase, market, or provide other goods and services related to the scope of the IEEE Standard. Furthermore, the viewpoint expressed at the time a standard is approved and issued is subject to change brought about through developments in the state of the art and comments received from users of the standard. Every IEEE Standard is subjected to review at least every five years for revision or reaffirmation. When a document is more than five years old and has not been reaffirmed, it is reasonable to conclude that its contents, although still of some value, do not wholly reflect the present state of the art. Users are cautioned to check to determine that they have the latest edition of any IEEE Standard.

Comments for revision of IEEE Standards are welcome from any interested party, regardless of membership affiliation with IEEE. Suggestions for changes in documents should be in the form of a proposed change of text, together with appropriate supporting comments.

Interpretations: Occasionally questions may arise regarding the meaning of portions of standards as they relate to specific applications. When the need for interpretations is brought to the attention of IEEE, the Institute will initiate action to prepare appropriate responses. Since IEEE Standards represent a consensus of all concerned interests, it is important to ensure that any interpretation has also received the concurrence of a balance of interests. For this reason, IEEE and the members of its societies and Standards Coordinating Committees are not able to provide an instant response to interpretation requests except in those cases where the matter has previously received formal consideration.

Comments on standards and requests for interpretations should be addressed to:

Secretary, IEEE Standards Board
445 Hoes Lane
P.O. Box 1331
Piscataway, NJ 08855-1331
USA

<p>Note: Attention is called to the possibility that implementation of this standard may require use of subject matter covered by patent rights. By publication of this standard, no position is taken with respect to the existence or validity of any patent rights in connection therewith. The IEEE shall not be responsible for identifying all patents for which a license may be required by an IEEE standard or for conducting inquiries into the legal validity or scope of those patents that are brought to its attention.</p>

Authorization to photocopy portions of any individual standard for internal or personal use is granted by the Institute of Electrical and Electronics Engineers, Inc., provided that the appropriate fee is paid to Copyright Clearance Center. To arrange for payment of licensing fee, please contact Copyright Clearance Center, Customer Service, 222 Rosewood Drive, Danvers, MA 01923 USA; (508) 750-8400. Permission to photocopy portions of any individual standard for educational classroom use can also be obtained through the Copyright Clearance Center.

Introduction

(This introduction is not part of IEEE Std 848-1996, IEEE Standard Procedure for the Determination of the Ampacity Derating of Fire-Protected Cables.)

Many cable installations in nuclear and fossil fuel generating stations require the installation of fire stop, fire protective materials, coating, and electrical separation wrap materials over the cables or the raceway for fire protection or electrical separation purposes. Appendix R of the Code of Federal Regulations for Nuclear Equipment may require some electrical circuits enclosed in a fire-protective material. IEEE Std 634-1976 specifies requirements for cable penetration fire stops at fire rated walls and floors. Compliance with IEEE Std 384-1992 may require installation of a wrap material over free air-drop cables or solid covers on cable trays.

Building codes for commercial and industrial facilities in some states require power cables, used in emergency power systems, to remain functional during a fire exposure. This may also necessitate the use of the fire protective material.

As discussed in IEEE Std 690-1984, utility generating stations use cable ampacities provided in IEEE 835-1994 for conduits, spaced cable tray installations, and duct bank installations. NEMA WC51-1991/ICEA P-54-440 is used for cable installation in random filled open-top trays. Commercial, industrial, and non-utility owned generating stations utilize cable ampacities published in NFPA 70-1996, National Electric Code® (NEC®). The NEC permits the use of IEEE Std 835-1994 and NEMA WC51-1991/ICEA P-54-440 under the direction of engineers.

Fire-protection related products may reduce the heat transfer characteristics associated with the ampacities provided in IEEE Std 835-1994 and NEMA WC51-1991/ICEA P-54-440. In future revisions, these ampacity standards may incorporate these new installation conditions on cable ampacity. Not all products, however, may be covered by changes in the ampacity standards due to their limited use to the generating station market. Hence, ampacity testing to determine ampacity derating of fire-protected cable systems is necessary.

Several analytical cable ampacity methods are listed in the bibliography to address fire stops, tray enclosure materials, and cable wrap material. The user may consider the applications of these analytical methods to avoid testing of minor differences in the installation of a given product.

This standard was prepared by the Task Group on Procedure for the Determination of the Ampacity Derating of Fire Protected Cables of the Subcommittee on Tests and Measurements of the Insulated Conductors Committee. The membership of the working group during the preparation of this draft was:

A. K. Gwal, *Chair*

J. L. White, Jr., *Vice Chair*

T. J. Al-Hussaini
P. Bhatia
K. Brown
E. A. Capouch
E. J. Coffey
E. J. D'Aquanno
J. Daly

P. A. Giaccaglia
A. Hiranandani
R. Jenkins
A. E. Kollar
R. Light
J. E. Merando
K. A. Petty
K. W. Prier

D. N. Priest
P. D. Skelly
M. Spurlock
W. Torok
J. R. Tuzinski
F. W. Van Nest
J. G. Waligorski

The following persons were on the balloting committee:

T. J. Al-Hussaini	John W. Hoffman	Gary A. Polhill
R. W. Allen, Jr.	Darrel R. Jeter	Ronald J. Ponist
W. O. Anderson, Jr.	C. Katz	Paul F. Pugh
R. H. Arndt	L. J. Kelly	Peter Ralston
T. P. Arnold	F. E. Kimsey	Greg P. Rampley
Hussein E. Badaly	Joel Kitchens	Robert A. Resuali
T. A. Balaska	H. T. Knox	R. B. Robertson
Anthony Barlow	Frederick B. Koch	Ralph W. Sann
Charles W. Blades	Albert Kong	George W. Seman
David T. Bogden	Donald E. Koonce	John F. Shimshock
Vincent J. Boliver	M. Kopchik, Jr.	Gilbert L. Smith
R. R. Borowski	Frank L. Kuchta	Joseph H. Snow
Ken E. Bow	F. E. La Gase	T. F. Stabosz
John E. Bramfitt	Jeffrey J. La Marca	Joseph L. Steiner
M. D. Buckweitz	Carl Landinger	Grover L. Stell, Jr.
R. R. Burghardt	J. S. Lasky	Frank M. Stepniak
Paul S. Cardello	Jack H. Lawson	Orloff W. Styve
Paul L. Cinquemani	Raoul H. Leuteritz	Mike D. Sweat
Wayne E. Cole	T. H. Ling	W. Keith Switzer
E. J. D'Aquanno	John V. Lipe	John Tanaka
J. M. Daly	Mark E. Lowell	James W. Tarpey
Russ Dantzler	G. Ludasi	Frank A. Teti
Joseph A. Di Stanzo	R. Luther	H. D. Thomas
C. Doench	G. J. Luzzi	William A. Thue
J. P. Dupont	Jeffrey P. Mackevich	Austin C. Tingley
G. S. Eager, Jr.	G. Allen MacPhail	William Torok
R. M. Eichhorn	M. A. Martin, Jr.	Duc B. Trinh
J. S. Englehardt	I. J. Marwick	S. E. Turner
S. L. Fitzhugh	M. S. Mashikian	Jack R. Tuzinski
A. Fitzpatrick	S. G. Mastoras	Donald A. Voltz
E. O. Forster	F. M. McAvoy	C. F. Von Hermann, Jr.
Ronald F. Frank	A. R. McCulloch	Richard L. Votoupal
R. D. Fulcomer	E. J. McGowan	Michael L. Walker
J. B. Gardner	A. L. McKean	Steven P. Walldorf
R. B. Gear	W. J. Mc	Edward M. Walton
Paul Giaccaglia	J. D. Medek	Daniel J. Ward
A. Godoshian	David J. Mintz	Roland H. W. Watkins
A. Gwal	J. A. Moran, Jr.	A. C. Westrom
V. Stan Harper	D. J. Nichols	Charles A. White
R. Hartlein	Harry E. Orton	John L. White, Jr.
H. C. Hervig	J. J. Pachot	William D. Wilkens
S. V. Heyer	Cutter D. Palmer	Robert O. Wilkinson
R. W. Higginbottom	Keith A. Petty	J. A. Williams
L. J. Hiivala	James J. Pickering	William G. Wimmer
Asit K. Hiranandi	Jan S. Pirrong	J. T. Zimnoch

The final conditions for approval of this standard were met on 5 August 1996. This standard was conditionally approved by the IEEE Standards Board on 20 June 1996, with the following membership:

Donald C. Loughry, *Chair*

Richard J. Holleman, *Vice Chair*

Andrew G. Salem, *Secretary*

Gilles A. Baril
Clyde R. Camp
Joseph A. Cannatelli
Stephen L. Diamond
Harold E. Epstein
Donald C. Fleckenstein
Jay Forster*
Donald N. Heirman
Ben C. Johnson

E. G. "Al" Kiener
Joseph L. Koepfinger*
Stephen R. Lambert
Lawrence V. McCall
L. Bruce McClung
Marco W. Migliaro
Mary Lou Padgett
John W. Pope

Jose R. Ramos
Arthur K. Reilly
Ronald H. Reimer
Gary S. Robinson
Ingo Ritsch
John S. Ryan
Chee Kiow Tan
Leonard L. Tripp
Howard L. Wolfman

*Member Emeritus

Also included are the following nonvoting IEEE Standards Board liaisons:

Satish K. Aggarwal
Alan H. Cookson
Chester C. Taylor

Lisa S. Young
IEEE Standards Project Editor

Contents

CLAUSE	PAGE
1. Overview	1
1.1 Scope	1
1.2 Purpose	1
2. References	2
3. Definitions	2
4. Test Description	3
4.1 General	3
4.2 Test specimens—protected cable systems	3
4.3 Test specimens—cable penetration fire stop	5
4.4 Test facility	6
4.5 Test procedure	11
5. Evaluation of test results	14
5.1 Normalizing test results	14
5.2 Ampacity derating factor	14
6. Documentation of testing	15
ANNEX	
Annex A (informative) Bibliography	16

IEEE Standard Procedure for the Determination of the Ampacity Derating of Fire-Protected Cables

1. Overview

1.1 Scope

This standard provides a detailed test procedure for determining the ampacity or derating factor in the following cable installation configurations:

- Block-out or sleeve type cable penetration fire stops
- Conduits covered with a protective material
- Tray covered with a protective material
- Cable directly covered or coated with a fire-retardant material
- Free-air drops enclosed with a protective material

The standard is applicable to cables installed and sized to IEEE Std 835-1994 for conduits and free-air drops, and NEMA WC51-1991/ICEA P-54-440 for cable tray.¹ IEEE Std 835-1994 does provide ampacities for cables in a tray with a fixed spacing and may be used for cable penetration fire stop configurations only.

This standard does not endorse the use of or provide application guidance for the installation of cable penetration fire stops and fire-protective materials. Cable designs are available that can withstand and remain functional during direct exposure to a fire. The user should refer to IEEE Std 634-1978 for the qualification requirements of cable penetration fire stops.

1.2 Purpose

The purpose of this standard is to provide a test procedure for use in establishing the ampacity or ampacity derating factor for cables installed in fire-protected conduits, trays, or free-air drops, cable penetration fire stops, or electrical separation wrap systems.

¹Information on references can be found in clause 2.

2. References

This standard shall be used in conjunction with the following standards. When the following standards are superseded by an approved revision, the revision shall apply.

IEEE Std 100-1992, The New IEEE Standard Dictionary of Electrical and Electronics Terms (ANSI).²

IEEE Std 384-1992, IEEE Standard Criteria for Independence of Class 1E Equipment and Circuits (ANSI).

IEEE Std 634-1978, IEEE Standard Cable Penetration Fire Stop Qualification Test.³

IEEE Std 690-1984, IEEE Standard for the Design and Installation of Cable Systems for Class 1E Circuits in Nuclear Power Generating Stations.⁴

IEEE Std 835-1994, IEEE Standard Power Cable Ampacity Tables.

NEMA WC3-1992/ICEA S-19-81, Rubber Insulated Wire and Cable for the Transmission and Distribution of Electrical Energy.⁵

NEMA WC7-1991/ICEA S-66-524, Cross-Linked Polyethylene Insulated Wire and Cable for the Transmission and Distribution of Electrical Energy.

NEMA WC8-1991/ICEA S-68-516, Ethylene-Propylene Insulated Wire and Cable for the Transmission and Distribution of Electrical Energy.

NEMA WC51-1991/ICEA P-54-440, Ampacities of Cables in Open-Top Trays.

NFPA 70-1996, National Electrical Code® (NEC®).⁶

Code of Federal Regulations, 10, Part 50, Appendix R, Fire Protection Program for Nuclear Power Facilities Operating Prior to Jan. 1, 1979.⁷

3. Definitions

3.1 ampacity derating factor: A numeric value representing the fractional reduction from a base ampacity cable rating. Ampacity derating factors are associated with specific installation conditions not presently addressed in the base ampacity.

3.2 ampacity correction factor: A numeric value equal to one minus the ampacity derating factor.

²IEEE publications are available from the Institute of Electrical and Electronics Engineers, 445 Hoes Lane, P.O. Box 1331, Piscataway, NJ 08855-1331, USA.

³IEEE Std 634-1978 has been withdrawn; however, copies can be obtained from Global Engineering, 15 Inverness Way East, Englewood, CO 80112-5704, USA, tel. (303) 792-2181.

⁴IEEE Std 690-1984 has been withdrawn; however, copies can be obtained from Global Engineering, 15 Inverness Way East, Englewood, CO 80112-5704, USA, tel. (303) 792-2181.

⁵NEMA publications are available from the National Electrical Manufacturers Association, 1300 N. 17th St., Ste. 1847, Rosslyn, VA 22209, USA.

⁶NFPA publications are available from Publications Sales, National Fire Protection Association, 1 Batterymarch Park, P.O. Box 9101, Quincy, MA 02269-9101, USA.

⁷This document is available from the Superintendent of Documents, U. S. Government Printing Office, P. O. Box 37082, Washington, DC 20013-7982.

3.3 cable penetration fire stop: Material, devices, or an assembly of parts providing cable penetrations through fire-rated walls, floors, or floor-ceiling assemblies, while maintaining required fire rating.

3.4 cable tray: A raceway resembling a ladder and usually constructed of metal. Other styles of trays include solid-bottom and channel type.

3.5 fire-protected cable systems: Cable systems to which a fire-protective enclosure material has been applied either in direct contact with the cables or applied over the raceway to protect cables from fire.

3.6 fire-retardant coatings: Material applied along the length of cables or in localized areas, as deemed necessary, to retard the flame propagation properties of cables in trays.

3.7 raceway: Any channel that is designed and used expressly for supporting or enclosing wires, cable, or bus bars. Raceways consist primarily of, but are not restricted to, cable trays and conduit.

3.8 reactive: Process by which a material undergoes a chemical or physical change.

4. Test Description

4.1 General

4.1.1 Applicability

This method shall apply to cables manufactured in accordance with NEMA WC7-1991/ICEA S-66-524, NEMA WC3-1992/ICEA S-19-81, or NEMA WC8-1991/ICEA S-68-516, and rated 600, 2000, 5000, 8000, or 15 000 V. This test is limited to cables installed in the following configurations:

- a) Tray with a fire-protected cable system where cables are arranged consistent with NEMA WC51-1991/ICEA P-54-440
- b) Conduit or free-air drop with a fire or electrical separation-protected cable system
- c) Block-out, conduit, or sleeve type and/or penetration type fire stop

4.1.2 Method of testing

Cable ampacity or ampacity derating factor shall be established by testing in accordance with the configurations shown in figures 1, 2, and 3. Test results may also be used to confirm analytical heat transfer models.

4.2 Test specimens—protected cable systems

4.2.1 Cable selection

The cables used in the ampacity tests are representative of all cable types and shall have copper conductor(s), 600 V rated cross-linked polyethylene insulation, and a chlorosulfonated polyethylene jacket. Depending on the specific test (as outlined below), the cables shall be rated 600 V and of either 3/C No. 6 AWG or 4/C No. 10 AWG construction. If a user opts to test using conduit sizes other than 1 in and 4 in (2.54 cm and 10.16 cm) (see 4.2.3), the number of cables shall be chosen to achieve a percentage fill of approximately 40%.

4.2.2 Cable fill

The ampacity of a protected cable system is dependent on a number of factors, including the actual cable depth in a tray, the number of conductors in a conduit and free-air drop, and the conductor size of the cables.

The ampacity derating factor of the barrier/wrap systems, however, is not dependent on these conditions. The following cable fill conditions shall be used:

- a) *Random filled tray.* Three layers of 3/C No. 6 AWG cables, 0.75 in (19 mm) diameter, 32 cables per layer, resulting in a depth of 2.25 in (57 mm) for the 24 in (610 mm) wide tray.
- b) *Conduit.* For the 4 in (100 mm) conduit, 12 3/C No. 6 AWG cables shall be used. For the 1 in (25 mm) conduit, a 4/C No. 10 AWG cable shall be used. These cables are chosen in order to achieve a percentage fill of approximately 40%.
- c) *Free-air drop.* Fill requirements do not apply.

4.2.3 Conduit

Conduit ampacity tests shall utilize 1 in and 4 in (25 mm and 100 mm) rigid steel conduits. Tests conducted using these two sizes shall be considered representative of all sizes provided that the fire-protective system installation methods and configurations are consistent across the entire size range. Where the installation methods, configurations, or fit differ according to conduit size, the user shall test sizes to bound the specific application. Conduits shall be a minimum of 12 ft (3660 mm) long. The conduit shall be isolated from its supporting structure by wooden blocks.

The surface emissivity of the conduit can affect test results. In order to provide a mechanism that will allow comparison of test results, the average surface emissivity of the conduit, along with the measuring device, shall be documented. The average surface emissivity of the conduit shall be determined at a minimum of nine points. Each test point should be a minimum of 1 ft (305 mm) from any other test point. Conduit couplings emissivities shall not be utilized in the calculation to determine the average surface emissivity.

In addition to the conduit, the junction boxes and pull boxes may also be enclosed with a protective material. Since the surface area of the boxes is significantly greater than the conduit, heat transfer is improved proportionally. Therefore, junction boxes and pull boxes do not need to be included in the ampacity test.

4.2.4 Tray

A commercially available 4 in (100 mm) deep, 24 in (610 mm) wide ladder-back style steel cable tray, a minimum of 12 ft (3660 mm) long, shall be used. The tray shall be isolated from the support by wooden blocks.

4.2.5 Free-air drop

Ampacity tests shall be conducted on free-air drop configurations consisting of 4/C No. 10 AWG and 12 3/C No. 6 AWG, respectively. Tests conducted using these two sizes shall be considered representative of all sizes provided that the fire-protective system installation methods and configurations are consistent across the entire size range. Where the installation methods, configurations, or fit differ according to size, the user shall test sizes to bound the specific application. Free-air drops shall be a minimum of 12 ft (3660 mm) long. The test specimen shall be supported to prevent sagging and shall be isolated from its supporting structure by wooden blocks.

4.2.6 Fire protective material

The protective material shall be representative of the installed product at maximum thickness. If the product is typically applied in a nonuniform manner, e.g., joints overlap when product is butted, then these sections shall be included in the test.

Some fire-protected cable systems utilize an end seal at the barrier or wrap ends in order to prevent the intrusion of hot gases or fire into the end of the tray or conduit. If the end seal is less than 6 in (150 mm), then the

seal may be excluded from the test. Otherwise, the end seal should be treated and tested in a similar manner to cable fire stop, except the wall section will be excluded.

4.3 Test specimens—cable penetration fire stop

4.3.1 Cable selection

The ampacity of the cable in a cable penetration fire stop varies with cable conductor size, conductor material, and manner of cable installation outside the fire stop. Tests conducted using a 600 V 3/C No. 12 AWG, copper conductor with cross-linked polyethylene insulation and an overall chlorosulfonated polyethylene jacket shall be considered representative of other voltage ratings, conductor sizes, insulating materials, and copper or aluminum conductors installed in random filled tray. Tests on single conductor 2/0 AWG aluminum conductor 600 V, with cross-linked polyethylene insulation and a chlorosulfonated polyethylene jacket shall be considered to be representative of cables installed in trays with maintained spacing. Tests performed using copper conductor cables may be used only to establish the derating factors for applications using copper conductor.

In cable bus applications, where larger conductor sizes are generally used, cable specimen shall be the smallest conductor in the anticipated use range. Aluminum conductor material shall be used, unless design is limited to copper conductors, in which case copper conductor may be used.

4.3.2 Cable fill

The tray shall be filled to a 1 in (25 mm) depth. The corresponding current in NEMA WC51-1991/ICEA P-54-440 shall be applied.

Ampacity tests on fire stops installed in trays with maintained spacing (per IEEE Std 835-1994) shall be conducted on a single layer of 2/0 cables separated by one diameter.

Plant-specific design conditions may be tested. However, the results may not be extrapolated to lower percentage filled cable trays.

Conduit fill shall be identical to that specified in 4.2.2.

4.3.3 Conduit

The conduit specimen shall be identical to that described in 4.2.3, except that the length of the conduit shall be 20 ft (6100 mm). No fire-protective material shall be applied to the conduit other than the fire stop.

4.3.4 Tray

Tray specimen shall be identical to that described in 4.2.4, except that the length of the tray shall be 20 ft (6100 mm) plus the width of the wall. No fire-protective material shall be applied to the tray other than the fire stop.

4.3.5 Floor/wall assemblies

The type of floor/wall construction and thickness affect the ampacity derating of the system. Thicker floors/walls shall be representative of thinner floors/walls of the same construction. Floors/walls constructed of lower thermal conductive materials shall be representative of floors/walls of higher thermal conductive materials.

The floor/wall assembly shall maintain a minimum of 24 in (610 mm) from its outer edge to the edge of the blackout.

For floor assemblies, the raceways may contain 90 ° bends located at a minimum of 24 in (610 mm) from each surface of the floor assembly.

4.3.6 Fire stop design

The fire stop configuration to be ampacity tested shall be representative of the maximum permitted installation tolerances, in contrast to fire tests, which are typically conducted on fire stops at the minimum tolerance.

4.4 Test facility

4.4.1 Test Enclosure

The ampacity test shall be conducted in an insulated enclosure as shown in figure 4, such that the temperature around the specimen shall be controlled to $40\text{ °C} \pm 2\text{ °C}$ ($104\text{ °F} \pm 3.6\text{ °F}$). The floors of the enclosure may be insulated with 3/4 in (19 mm) plywood. The intent of enclosure construction is to ensure that interior surface temperatures reflect the ambient environment and that there is an even temperature within the enclosure. Drafts on the test specimen shall be limited. The temperature inside the enclosure shall be measured at no less than three places 1 ft (300 mm) from the specimen, and in the horizontal plane of the test specimen. The temperature of the enclosure shall be taken as the average of the steady state measurements.

4.4.2 Test specimen installation

4.4.2.1 Tray

The tray is to be uniformly loaded with a single type of cable. The cables shall be installed in an orderly, symmetric manner, so as to limit the flow of air through the cables and to ensure repeatability. Cable tie wraps shall not be used within the tray.

The cables shall be connected as a single series electrical circuit.

When testing the protected cable systems, a section of insulating blanket may be placed at the ends of the tray to minimize axial heat flow, such that the average values for the thermocouples at locations 1 and 3 (see figure 1) are within $\pm 4\text{ °C}$ (7.2 °F) of the average value for location 2.

4.4.2.2 Conduit

The cables shall be pulled into the conduit after installation of the thermocouples. No pulling lubricant shall be used. When three single conductor cables are utilized for the conduit tests, the cables shall be bundled with stainless steel tie wraps or glass cloth electrical tape to ensure thermocouple placement is maintained during insertion or removal.

The cables shall be connected as a single series electrical circuit.

A section of insulating blanket may be placed at the ends of the conduit to minimize axial heat flow, such that the average values for the thermocouples at locations 1 and 3 (see figure 2) are within $\pm 4\text{ °C}$ (7.2 °F) of the average for location 2.

4.4.2.3 Free-air drop

The cables shall be connected as a single series electrical circuit. When multiple cables are utilized for these tests, the cables shall be bundled with stainless steel tie wraps or glass cloth electrical tape to ensure thermocouple placement is maintained.

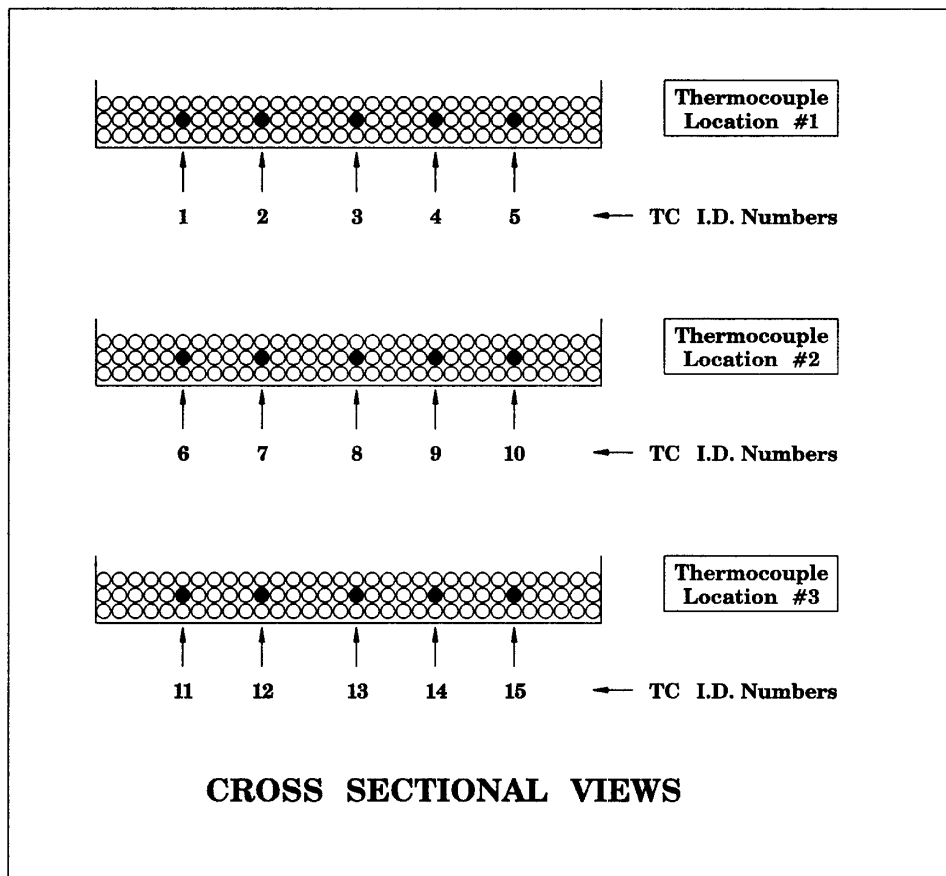
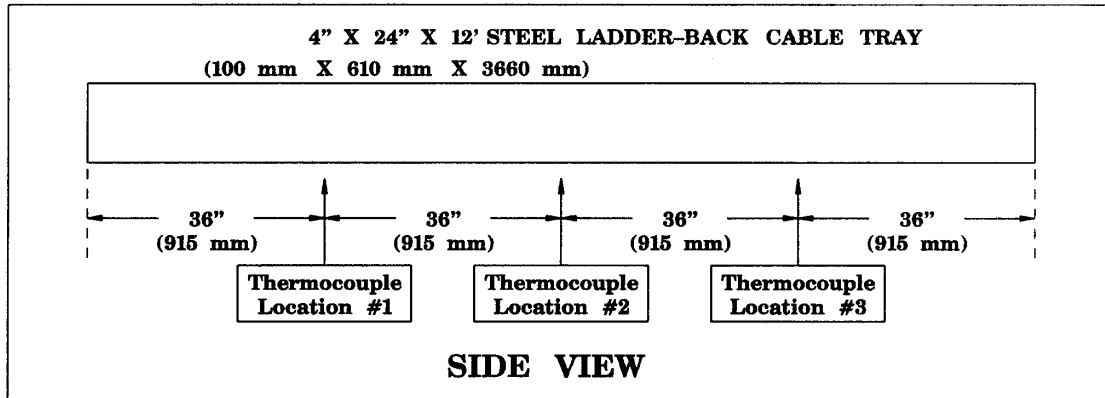

Figure 1—Tray configuration—protective cable system

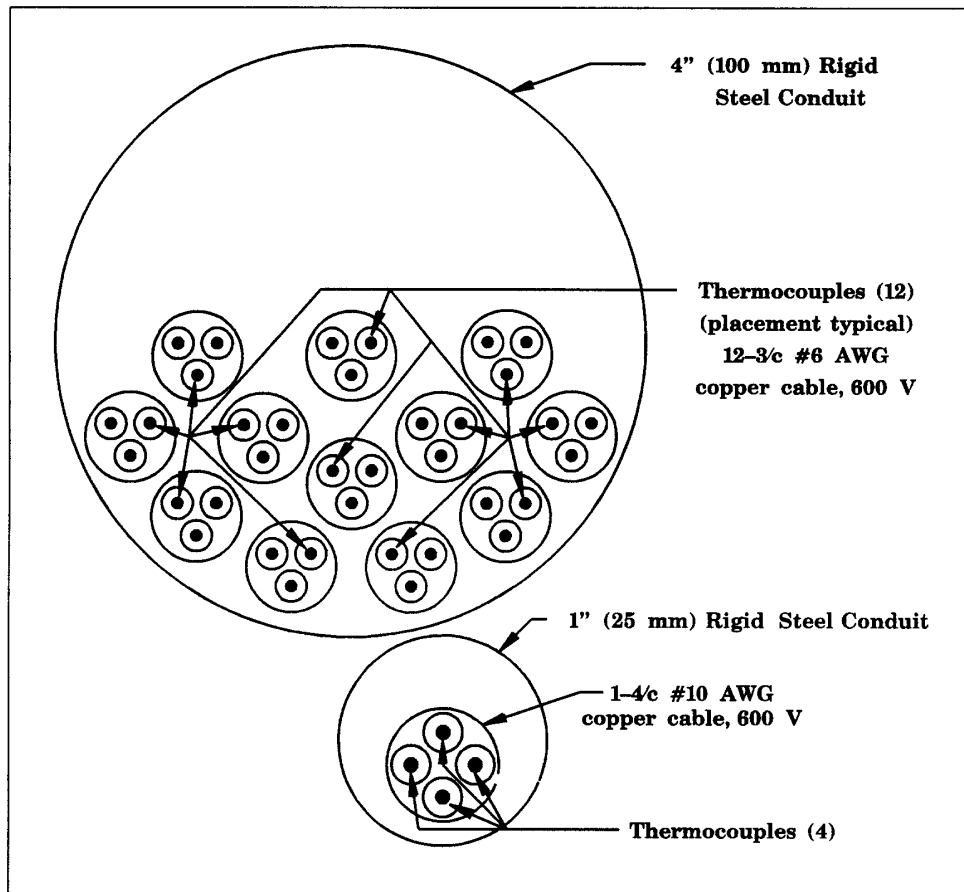
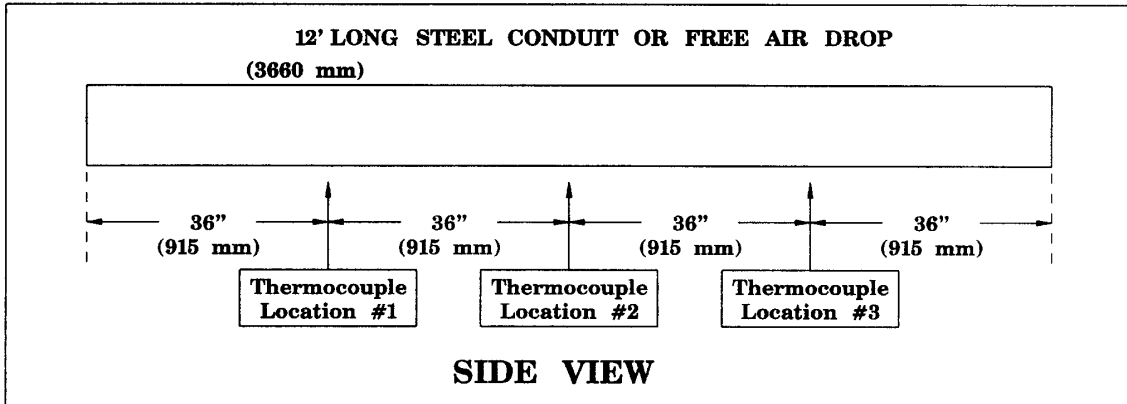

Figure 2—Conduit and free-air drop configurations—protective cable system

A section of insulating blanket shall be placed at ends of the free-air drop to minimize axial heat flow, such that the average values for the thermocouples at locations 1 and 3 (see figure 2) are within ± 4 °C (7.2 °F) of the average for location 2.

4.4.2.4 Cable penetration fire stop

The cables and raceway penetrating the fire stop floor/wall shall be installed in an identical fashion as during fire testing. This may include special spacing requirements. If the fire stop design permits installation of the cables on the tray rungs or directly on the blockout surface, the bounding condition is considered to be with the cables placed on the tray rungs.

4.4.2.5 Orientation

The fire-protected raceway test specimens shall be mounted horizontally in order to model worst case orientation and to prevent a “chimney-effect.” In the case of fire stop tests, open ends of enclosed raceways shall be sealed to eliminate air movement.

4.4.2.6 Installation of fire protective systems

The tray and conduit is to be raised off its support after completion of the baseline tests. The protective system shall then be applied in accordance with the method established in the fire or electrical separation testing. The entire assembly shall be lowered back onto the supports while ensuring the assembly is not cracked or otherwise distorted. If the protective system can be removed without disturbing the cables or thermocouple placement, then the baseline tests may be performed before or after testing the protective cable system.

If the product undergoes a curing operation, the test specimen’s dry state shall be established by the manufacturer and achieved prior to the test through natural or artificial drying.

If the product is reactive at temperatures below 90 °C (194 °F), then the equilibrium time should be extended based on specific analysis.

4.4.3 Thermocouple selection and placement

Thermocouples shall be a maximum of 24 AWG, Type T special grade–copper/constantan, with an accuracy of ± 0.5 °C (0.9 °F), or other thermocouple types that have been calibrated to the same level of accuracy. Thermocouple wire shall have waterproof insulation. Thermocouples shall be placed directly against the conductor.

To attach the thermocouple junction to a multiconductor cable, make an approximately 2 in (50 mm) long slit in the outer jacket of the cable, to expose the insulated conductors. Then make a 1 in (25 mm) slit in the insulation to expose the conductor as shown in figure 5. Insert the thermocouple junction in direct contact with the conductor strands. Close the insulation slit and seal the slit with a single layer of glass-reinforced electrical tape. Reposition the outer jacket and seal with a single layer of glass-reinforced electrical tape.

To attach the thermocouple junction to a single conductor cable, make a 1 in (25 mm) slit in the jacket/insulation system to expose the conductor. Insert the thermocouple junction in direct contact with the conductor strands. Close the jacket/insulation slit and seal with a single layer of glass-reinforced electrical tape.

The test is intended to identify the temperature of the hottest conductor within the center of the protected cable system and cable penetration fire stop. A set of thermocouples shall be installed at each of the vertical planes along the length of the cable as shown in figures 1, 2, and 3. The 1 in (25 mm) conduit and the small free-air drop shall have the thermocouples placed on all three conductors. Within the tray assembly, thermocouple leads shall remain in the layer in which they are installed and be routed out the end of the tray in the interstices of the cable mass. The 4 in (100 mm) conduit and the large free-air drop shall also have their thermocouple leads routed in the interstices of the cable mass.

For fire-protected raceways, the following number of thermocouples shall be placed in each vertical plane:

tray configuration	5
1 in (25 mm) conduit and small free-air drop	4
4 in (100 mm) conduit and large free-air drop	12

For ampacity tests of tray penetration fire stops, five thermocouples shall be placed on the conductors in the fire stop in accordance with figure 1. One additional thermocouple shall be placed at 2 ft (610 mm) intervals on one conductor of the center cable in the middle layer on each side of the firestop (see figure 3).

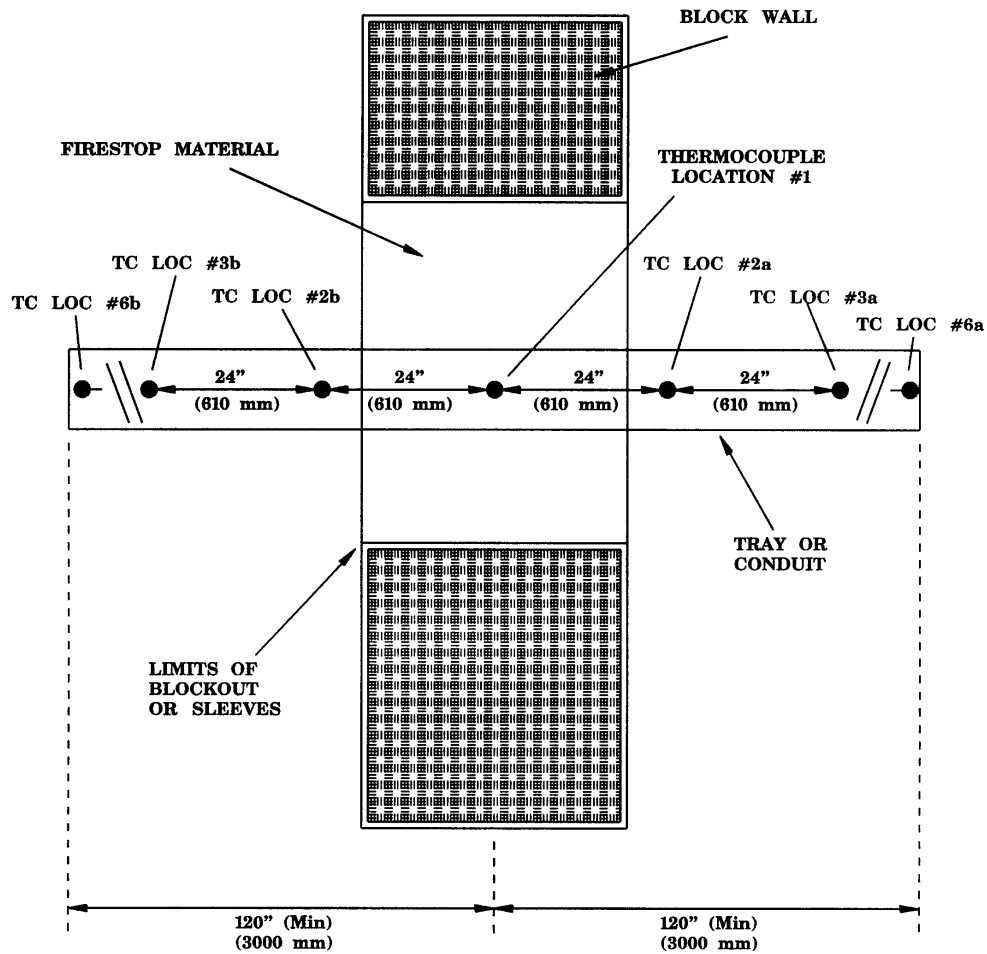

Figure 3—Configuration—cable penetration fire stop

For ampacity tests of conduit or free-air drop penetration fire stops, five thermocouples shall be placed on the conductors in the fire stop in accordance with figure 2. One additional thermocouple shall be placed at 2 ft (610 mm) intervals on each side of the fire stop.

4.5 Test procedure

4.5.1 Baseline evaluation

At least one baseline test for each system, i.e., tray, conduit, free-air drop, shall be conducted in order to establish baseline ampacities. Baseline evaluation for a tray and conduit assembly shall be performed on the same physical specimen used for the derating test. Baseline and derating evaluations for free-air drops shall be performed using the same instrumented cable set.

4.5.2 Current source

The circuit shall be energized with a 60 Hz (rated frequency), single-phase source sufficient to cause the conductor to reach 90 °C (194 °F) at location 2 in figures 1 and 2, and location 1 in figure 3. The current shall be measured to an accuracy of $\pm 1.0\%$. The use of a constant-current amplifier is recommended since the increasing temperature changes the circuit load, i.e., conductor resistance. Alternatively, process control devices can be used to generate and maintain the current source.

4.5.3 Temperature measurement

All temperatures shall be recorded at intervals no greater than one minute. The current in each test circuit shall be adjusted to achieve a hot spot conductor temperature of $90\text{ °C} \pm 1\text{ °C}$ ($194\text{ °F} \pm 1.8\text{ °F}$) at location 2 for the protected cable systems and location 1 for cable penetration fire stop. The average temperature of thermocouple locations 1 and 3 for the protected cable systems shall each be within $\pm 4\text{ °C}$ (7.2 °F) of the average temperature reading at location 2. No restrictions are placed on the temperature readings at locations outside the cable penetration fire stop.

The cable circuit is considered to have reached steady state condition when:

- a) A minimum of 3 h has elapsed since the last adjustment of current level or perturbation of the system occurred.
- b) The rate of change of the average of thermocouple reading at the hot spot (location 2 for figure 4, and location 1 for figure 3) does not exceed $\pm 0.2\text{ °C}$ (0.36 °F) per hour for conduit, tray, and free-air drop.

Perturbation of the system conditions includes current adjustment, change in the internal temperature of the enclosure, and addition or removal of insulation on the ends of the tray, conduit, or free-air drop. Minor adjustment of current ($< 0.1\%$) required to keep the current constant is not considered a perturbation of the system.

In order to statistically assure thermal equilibrium, the conductor temperatures shall be averaged at each sampling period. A linear regression analysis using the least-squares method shall be performed on the data obtained over the preceding 60 min. The slope of the line shall be expressed in units of °C (or °F) per hour. When the absolute value of the slope becomes less than 0.2, equilibrium has been reached.

The degrees of freedom obtained by averaging many thermocouple locations, allows the precision to exceed the $\pm\text{°C}/\text{°F}$ limit of any one thermocouple.

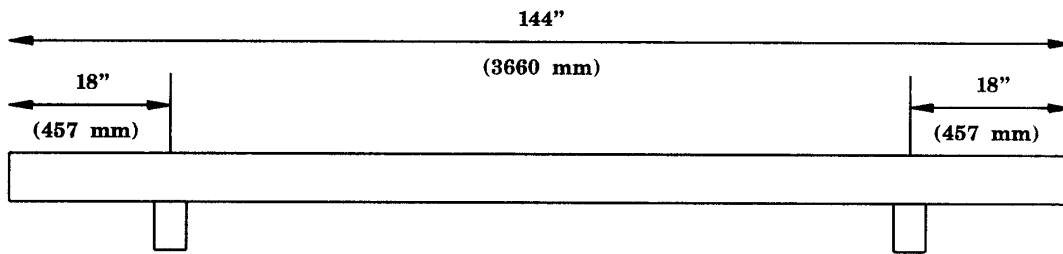
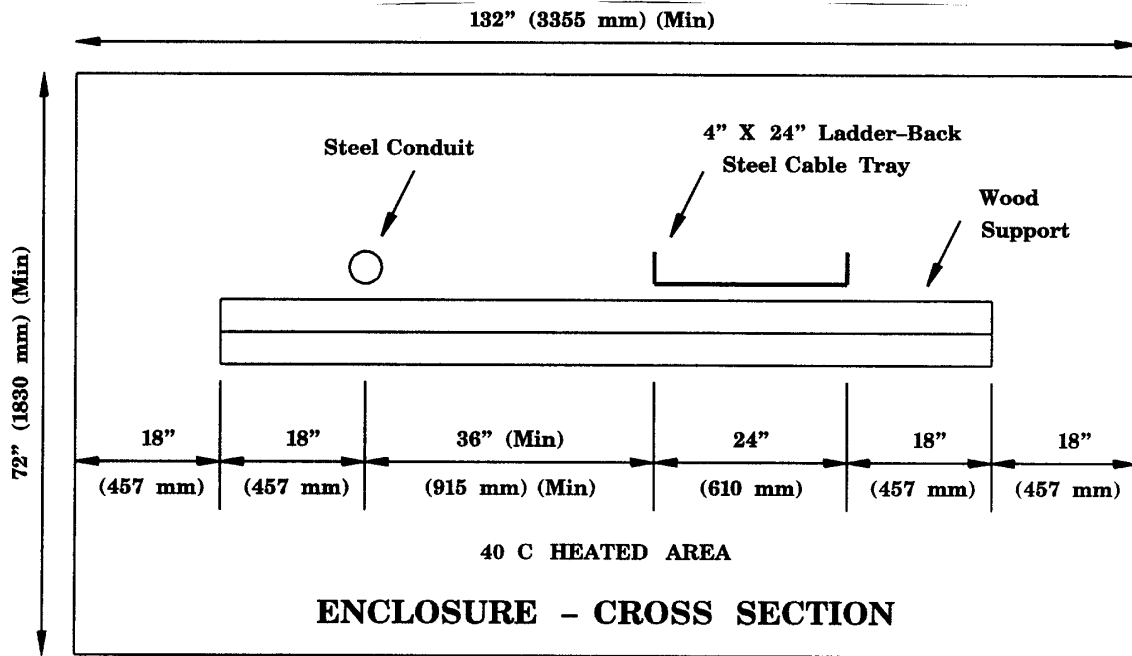

CONDUIT & TRAY SUPPORT POINTS

Figure 4—Enclosure and support requirements—protective systems

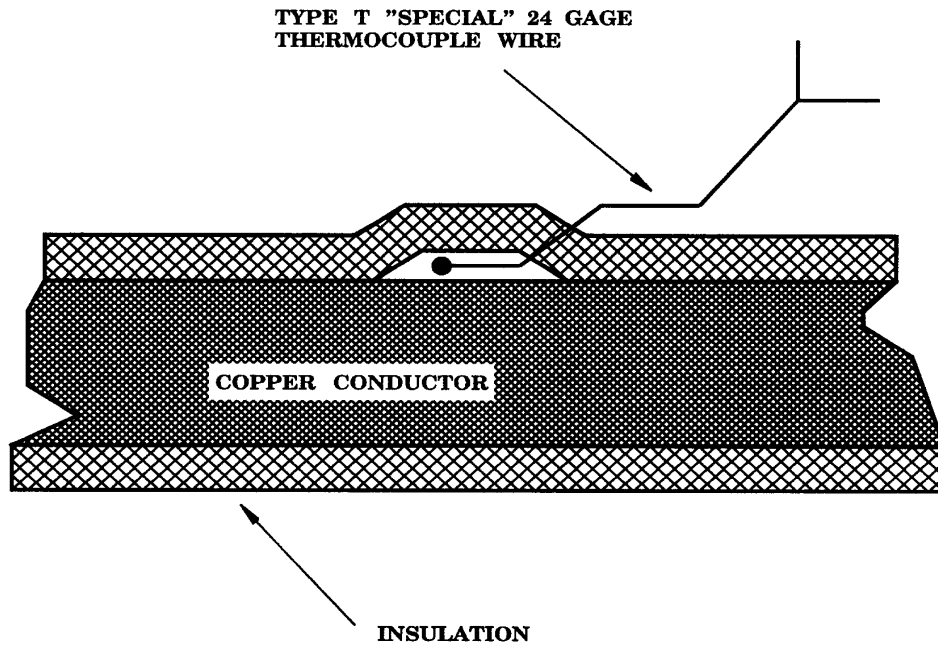

Figure 5—Thermocouple attachment to conductor

The equations for a linear regression using the least squares fit method are as follows:

$$Y = mX + b \tag{1}$$

$$\bar{X} = \sum \frac{X}{n} \tag{2}$$

$$\bar{Y} = \sum \frac{Y}{n} \tag{3}$$

$$m = \frac{\sum XY - \frac{\sum X \sum Y}{n}}{\sum X^2 - \frac{(\sum X)^2}{n}} \tag{4}$$

$$b = \bar{Y} - m\bar{X} \tag{5}$$

where

- Y is the average conductor temperature in degrees
- X is the time increment (min)
- m is the slope of line (degrees/min)
- b is the Y-axis intercept, in degrees

4.5.4 Enclosure temperature

The temperature within the test enclosure shall be controlled to 40 ± 2 °C (104 ± 3.6 °F). Some induced air movement within the enclosure is necessary to achieve uniform steady-state temperatures. Care should be taken to avoid direct air currents against the test specimens. The method of ambient temperature control within the test enclosure is important. Care should be taken to avoid any additional heat loading on the cables by radiation from a heat source.

5. Evaluation of test results

5.1 Normalizing test results

After equilibrium has been achieved, the final conductor temperature and the ambient temperature may not match 90 °C (194 °F) and 40 °C (104 °F), respectively. The results of the baseline and the fire-protected cable system tests should be normalized using equation 6, as shown below. The conductor temperature shall be the hottest conductor temperature at location 2 for the protective cable system and location 1 for cable penetration fire stop. The final temperatures shall be within the limits established in 4.5.4 and 4.5.3.

$$I' = I \sqrt{\frac{(T_c' - T_a')(\alpha + T_c)}{(T_c - T_a)(\alpha + T_c')}} \quad (6)$$

where

- I is test current at equilibrium, amperes
- T_c is hottest conductor temperature at center at equilibrium, °C
- T_a is measured enclosure ambient temperature, °C
- I' is normalized current, amperes
- T_c' is normalized conductor temperature= 90 °C
- T_a' is normalized ambient temperature= 40 °C
- α is 234.5 for copper or 228.1 for aluminum

5.2 Ampacity derating factor

Using the normalized current, as determined from 5.1, an ampacity derating factor can be calculated using the results of the baseline test and the protected cable system or cable fire stop. The ampacity derating factor (ADF) and ampacity correction factor (ACF) shall be calculated using equations 7 and 8. The user may find it more convenient to express the ampacity results as ampacity correction factor (ACF) for calculation purposes. ACF is applied in a similar fashion as conduit grouping factors and ambient temperature correction factor as shown in IEEE Std 835-1994.

$$ADF = \frac{(I_o - I_f)}{I_o} 100 \quad (7)$$

$$ACF = \frac{I_f}{I_o} \quad (8)$$

where

- I_o is the normalized current for the baseline condition, amperes
- I_f is the normalized current for the passive fire-protected cable system or cable penetration fire stop system, amperes
- ADF is the ampacity derating factor, %
- ACF is the ampacity correction factor

Ampacity derating factors shall be expressed in conjunction with reference to its baseline ampacity standard. This is especially important for cable penetration fire stops where the cable installation method outside the wall has a major influence on the resulting derating factor. Cable fire stop ampacity derating factor is also restricted in terms of conductor size and material.

Examples illustrating how the ampacity derating factors should be expressed are shown below.

- ADF=18%, Floor Assembly Fire Stop Penetration, Product design AAA, applied against IEEE Std 835-1994 *conduit in air ampacities* for 12 AWG aluminum or copper conductors and larger.
- ADF=7%, Wall Assembly Fire Stop Penetration, Product design AAA, applied against IEEE Std 835-1994 *conduit in air ampacities* for 1000 kcmil copper conductors or 1250 kcmil aluminum conductor and larger.
- ADF=20%, Fire Protective Material—Tray Application, Product design BBB, when applied against NEMA WC51-1991/ICEA P-54-440.
- ADF=18%, Electrical Separation Wrap—Free-Air Drop, Product design CCC, when applied against IEEE Std 835-1994 *in free air ampacities*.

6. Documentation of testing

The test report and the resulting derating factor shall include the following documentation:

- a) Description of the test configuration
- b) Date of the test
- c) Location of the test
- d) Description of the test equipment and test articles
- e) Calibration documentation of all thermocouples
- f) Qualification and certification for test personnel
- g) Test procedures used
- h) Ampacity values determined and accompanying equilibration temperatures
- i) Quality control records for:
 - 1) Test article construction
 - 2) Qualification and certification for installation and inspection personnel
 - 3) Identification and installation of fire barrier material
 - 4) Thermocouple locations
 - 5) Cables, size, type, and location
 - 6) Actual tray and conduit cable fill, and calculated depth of cable fill, as defined in NEMA WC51-1991/ICEA P-54-440
- j) Computer printout and graphic results of the ampacity test
- k) All raw data
- l) 35 mm photographic coverage of the test project
- m) Documentation that product does or does not react at temperatures below 90 °C (194 °F)
- n) Documentation that moisture equilibrium has been achieved
- o) Average surface emissivity
- p) Device used to obtain surface emissivity reading

Annex A

(informative)

Bibliography

[B1] Stolpe, J., "Ampacities for Cables in Randomly Filled Trays," *IEEE Transactions on Power Apparatus and Systems*, vol. PAS 90, pp. 962-973, 1971.

[B2] Nemeth, C. W.; RackLiffe, G. B.; and Legro, J. R., "Ampacities for Cables in Trays with Firestops," *IEEE Transactions on Power Apparatus and Systems*, vol. PAS 100, no. 7, July 1981.

[B3] Herter, V. J.; Barry, R. E.; and Began, T. A., "Ampacity Test of a Silicone Foam Firestop in a Cable Tray," *IEEE Transactions on Power Apparatus and Systems*, vol. PAS 100, no. 7, July 1981.

[B4] Petty, K. A., "Ampacity of Wrapped Cables," *IEEE Transactions on Power Delivery*, vol. 3, no. 1, Jan. 1988.

[B5] Esteves, O. M., "Derating Cables in Trays Traversing Firestops or Wrapped Fireproofing," *IEEE Transactions on Power Apparatus and Systems*, vol. PAS 102, pp. 1478-1481, 1983.

[B6] Save, P., and Engmann, G., "Fire Protection Wrapped Cable Tray Ampacity," *IEEE Transactions on Energy Conversion*, vol. 4, no. 4, 1989.

[B7] Hiranandani, A. K., "Rating Power Cables in Wrapped Cable Trays," *IEEE Transactions on Power Delivery*, vol. 3, no. 1, January 1988.